

DETACHABLE HATCH
DETACHABLE HATCH. OUTLET HAND VALVE LOCATED BEHIND HATCH

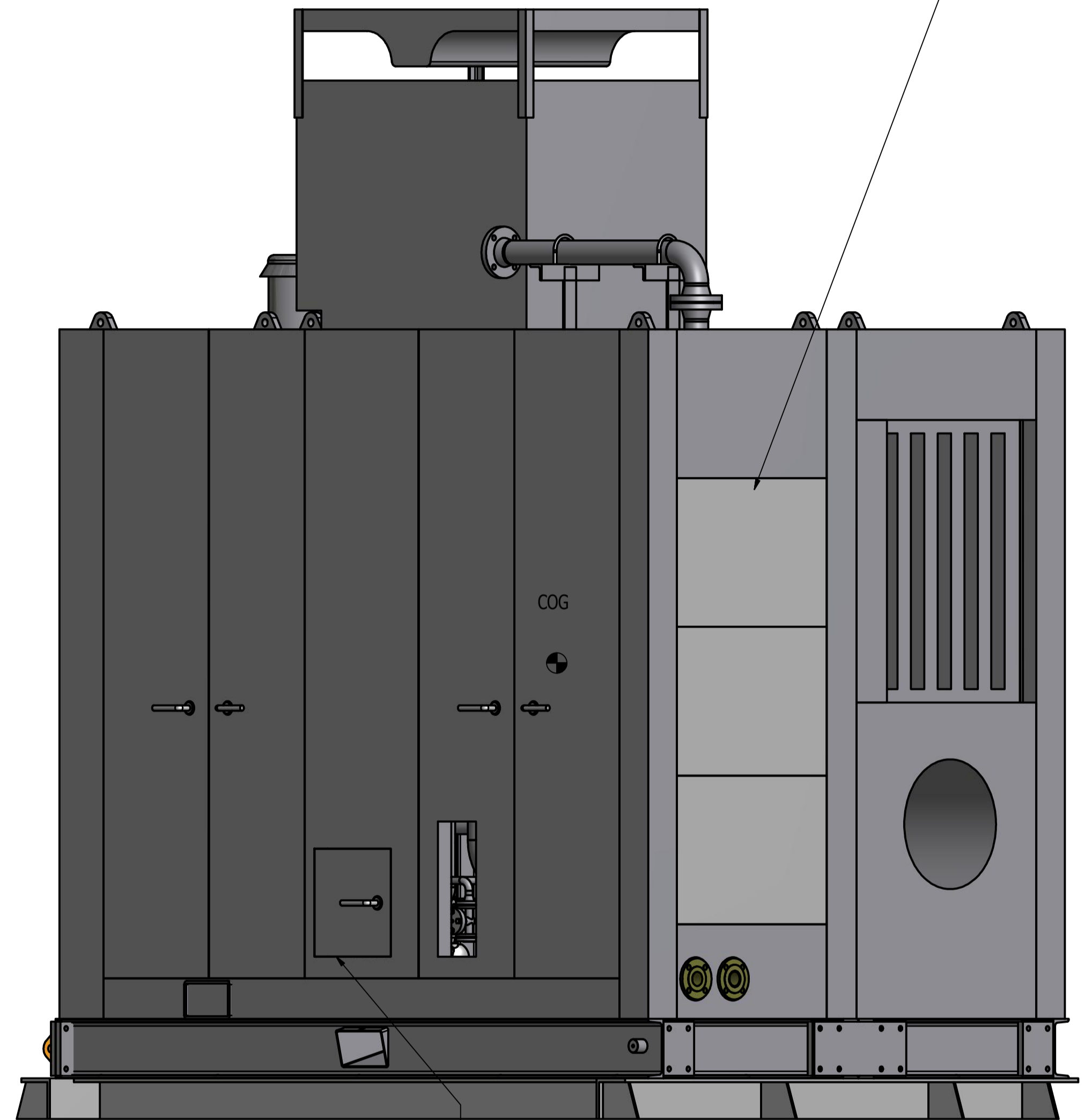

HINGED HATCH TO BE FITTED FOR ACCES VALVES

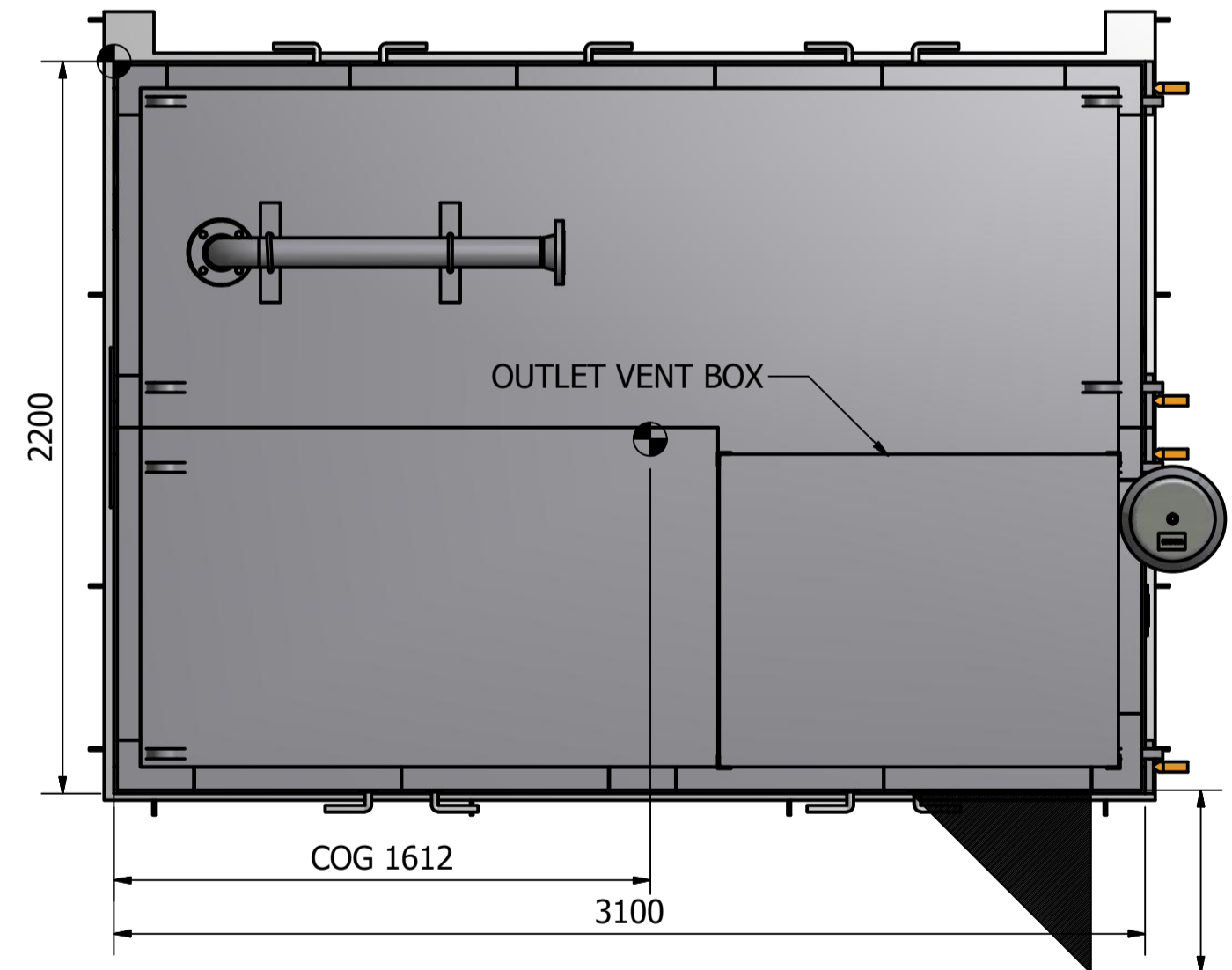

550 REQUIRED DISTANCE FOR OPEN DOORS

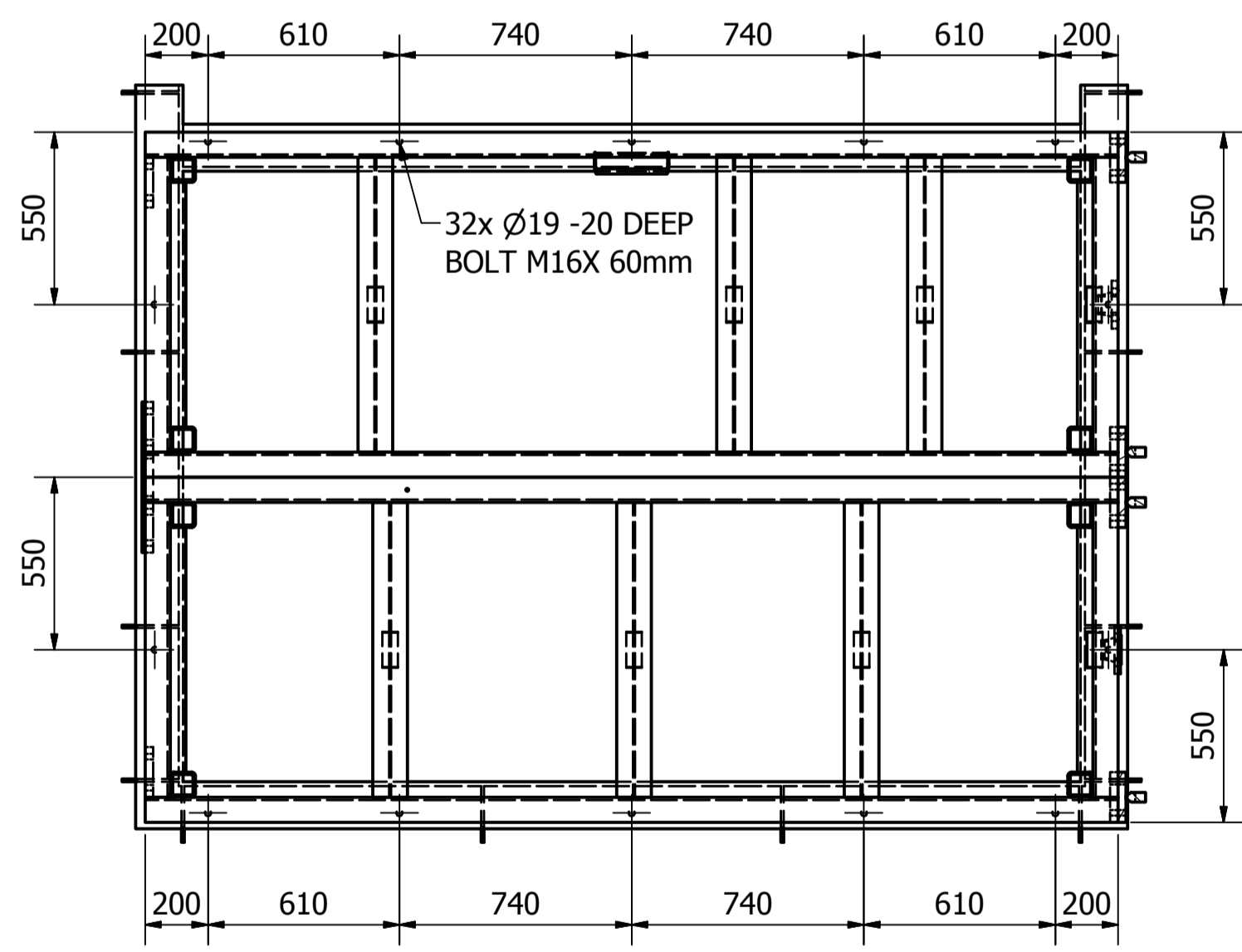

SECTION C-C
(1 : 20)

Contract	P.O. No.
-	-
Supplier Document Review	
Contractor's review acceptance code to documentation submitted for review and acceptance.	
1	<input checked="" type="checkbox"/> Accepted
2	<input type="checkbox"/> Accepted with comments - Revise and resubmit
3	<input type="checkbox"/> Not accepted - Revise and resubmit.
4	<input type="checkbox"/> For information only
Sign	Date
Jan-A. Hansen	-

NOTES:
AIR COMPRESSOR WILL BE DELIVERED IN 2 SECTIONS FOR HANDLING, LIFTING AND TRANSPORTATION SIZE FOR EACH. SKID LxWxH 3100x1100x2813
INTERCONNECTION PIPING BETWEEN SKIDS WILL BE SHIPPED LOOSE AND MOUNTED AFTER INSTALATION OFF
SKIDS OPERATING WEIGTH: 11000KG INCLUDE ENCLOSURE
DRY WEIGTH: 9500KG INCLUDE ENCLOSURE

CONTRACTOR:
aibel
SUPPLIER:
K.LUND Offshore.as
SUPPLIER DRAWING NUMBER:
18.432-GA-021

REV.	DATE	REASON FOR ISSUE	PREPARED	CHECKED	APPROVED
06	04.07.2014	Re-issued for construction	ET	RJ	SS
05	13.01.2014	Re-issued for construction	ET	RJ	SS
04	30.09.2013	Re-issued for construction	ET	RJ	SS
03	16.07.2013	Re-issued for construction	ET	RJ	SS
02	17.06.2013	Issued for construction	ET	RJ	SS
01	07.02.2013	Issued for bid	ET	AH	SS



INSTALLATION:
Norne
DRAWING TITLE:
GA AIR COMPRESSOR #1/2/3

1:15	A1	-	M47	63	C049-3085-M-XA-0001-02	06
SCALE	SIZE	CONTR. NO	AREA	SYSTEM	DRAWING NUMBER	REV.